

LENTIL



USE:

Interiors:

- schools
- canteens
- public buildings
- offices
- corridors
- and others...

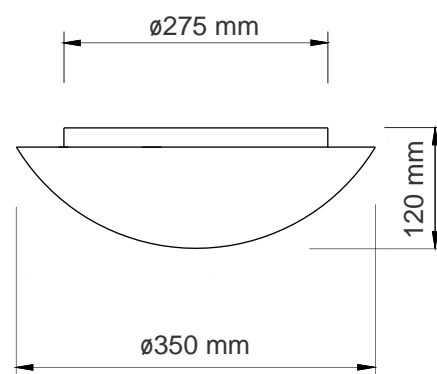

Protection degree: IP 43
Diffuser: UV stabilized plastic
Lampshade colour: white
Power supply: 230V 50Hz
Lamp: 2 x 23W / E27
Body: steel
Finishing of body: white powder coated



- Ceiling or wall light in the shape of a lens with a diameter of 35 cm perfectly shines the light into the room, does not glare and provides natural lighting across the room.
- The shade is made of UV stabilized plastic. In comparison with glass diffuser the plastic lampshade is much safer. Therefore is suitable for public spaces such as schools, canteens, offices, corridors, etc.
- Simple and functional design gives the proper elegance.